

MEASURING THE WORLD OF LIGHT (part 2)

GONIOPHOTOMETRY AND SPECTRORADIOMETRY FOR SSL LIGHT SOURCES

The first part of the article series *Measuring the World of Light* was published in the *LICHT* issue 11-12/2014 [1]. It presented some important information from the new draft standard CIE DIS 025:2014 [2]. Part 2 now discusses the correct application of the standard in goniophotometry based on a range of comparison measurements. It compares measurements from different light sources taken with a turning luminaire goniometer with measurements carried out using a luminous flux integrator which maintains the burning position of the light source. This method uses both a high-quality spectroradiometer and a conventional photometer as a detector. The influence exerted by the burning position of various light sources on luminous flux measurements is a particular focus of the investigation. The effectiveness of the method for correcting the burning position defined in the draft standard CIE DIS 025:2014 is also reviewed. The article then also presents sample measurements to demonstrate the versatile characterization options for Solid State Lighting (SSL) light sources with a goniospectroradiometer.

GONIOPHOTOMETRY

Goniophotometers are normally used for the determination of illuminance and luminous intensity distributions. They are also applied for measurements of the total luminous flux by appropriate numerical integration of these distributions. Although determining the luminous flux with a goniophotometer is much more time-consuming by comparison with measurement in an integrating sphere, it is significantly more accurate.

This method adds up the measured values for illuminance in all the angle positions around a light source, as shown in the diagram in Fig. 1. This approach is preferred by leading national laboratories which provide reference values for other measurement procedures.

A goniophotometer is absolutely essential if parameters like partial luminous flux or beam angle are to be determined for light sources, as is the case in characterization for

energy efficiency [3]. The goniophotometer unit can be used with both a conventional photometer and a spectroradiometer depending on the test objective.

Using a photometer head as a detector allows very fast measurements to be carried out for luminous flux and luminous intensity distribution. The photometer must have good adjustment to the sensitivity function of the human eye $V(\lambda)$ in order to measure SSL light sources. The general $V(\lambda)$ mismatch index f_1' is normally used to represent this property. f_1' must be less than or equal to 3% in order to carry out measurements in conformity with the standard [2].

If a spectroradiometer is used instead of the photometer, the system is known as a goniospectroradiometer. It allows the spatial distribution to be measured for all relevant photometric and colorimetric parameters, alongside luminous flux distribution curves, and color coordinates, correlated color temperature (CCT), and even the color rendering index (CRI).

A high color rendering index is an increasingly important criterion impacting on decision-making when developing and marketing LED light sources.

Goniospectroradiometry is therefore a universally important tool for defining all the characteristics of SSL light sources. Furthermore, SSL light sources with narrowband spectral components can be measured with a significantly higher level of accuracy. The spectroradiometer must cover at least the wavelength range of 380 to 780 nm with a wavelength accuracy of less than 0.5 nm and a maximum bandwidth of 5 nm [2]. It is even better if the entire visible spectrum of 360 to 830 nm [4] is covered.

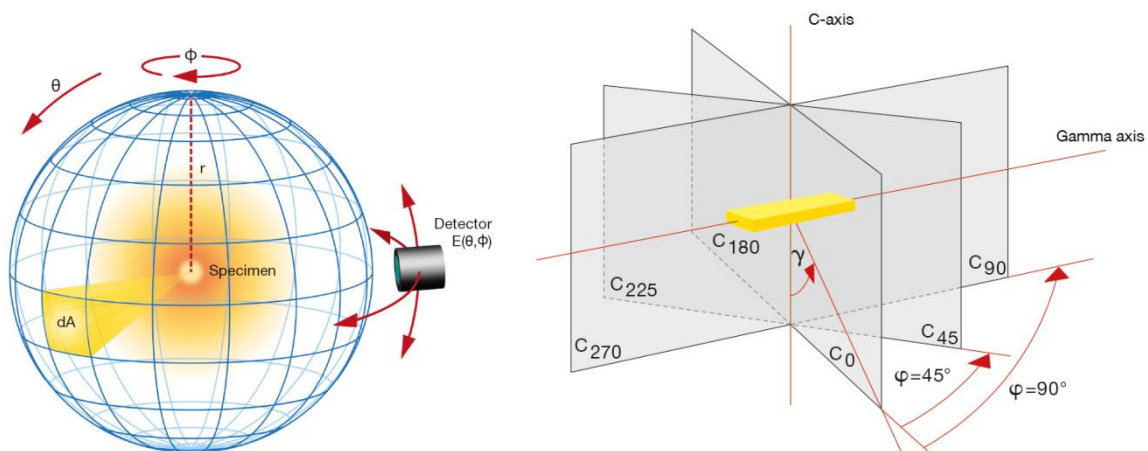

Image 1: Integration of the illuminance E to luminous flux Φ_v (left) and definition of the C, γ coordinate system (right). C represents the angle ϕ and γ the angle θ in the sphere coordinates.

The American standard IES LM-79-08 has been used worldwide because there was no international standard up to now. However, this standard only recommends type C goniophotometers for the measurement of SSL light sources [5]. Type C goniophotometers are supplied in different versions with a moving detector or a rotating mirror. The systems in both versions are very expensive, large and require a great deal of space for far-field measurements. A turning luminaire goniometer which uses a C, γ coordinate system in accordance with CIE 121-1996 (Figure 1 right) is conversely much more compact. This means that a turning luminaire goniometer can be set up in a laboratory with a standard ceiling height by contrast with a rotating-mirror goniometer. However, the burning position of the light source is changed during measurement when using a turning luminaire goniometer.

The LM-79 recommends measuring the device under test (DUT) in the operating orientation in order to mitigate potential differences in convective cooling, although the burning position of individual LEDs is actually irrelevant in SSL light sources. The new CIE DIS 025:2014 draft standard relaxes this restriction and specifies the tolerance condition that the device under test needs to remain continuously in its specified burning position during the stabilization and test period [2]. If this condition is not complied with, the measurements have to be corrected to match the behavior of the device under test, e.g. by using an auxiliary photometer method.

This article is based on a study which investigated the influence of the burning position for different light sources using the two measurement systems – a so called luminous-flux integrator, which maintains the burning position, and a turning luminaire goniometer. If necessary, a position correction is applied for measurements taken with the turning luminaire goniometer.

TURNING LUMINAIRE GONIOMETER

Figure 2 shows a turning luminaire goniometer which uses a C, γ coordinate system in conformity with CIE 121-1996. The photometer head can be aligned on the optical axis of the device under test at any fixed distance along the C-axis of the goniometer. The distance of the measuring head should be selected so that it is at least 15 times the longest dimension of the source. This guarantees that the detector is always positioned in the far field of the luminaire in conformity with the most stringent requirement of CIE

DIS 025:2014 for narrow-angled sources [2]. The photometer head is shielded by a tube against unwanted stray light. Alternatively, an optical probe for a spectrometer can be used as a detector.

The luminaire is rotated about the C and the γ -axis of the goniometer, i.e. it changes its burning position during the measurement. It is important to ensure before every measurement that the luminaire is burned in appropriately in conformity with the specifications of IES LM-79-08 and CIE DIS 025:2014. All investigated light sources were therefore burned in for at least an hour before the measurement.



Image 2: Turning luminaire goniometer (left) and measuring probe enclosed in the stray light tube on a stand (right).

LUMINOUS FLUX INTEGRATOR

A so called luminous flux integrator can be used to characterize the illuminant in the required burning position. This upgrade option of the turning luminaire goniometer has an integrator arm and a separate sample holder which convert the instrument to a goniometer with a rotating detector. This type of goniometer allows the device under test to remain in position unchanged and the detector moves on the surface of a sphere around the luminaire (Fig. 3). The function of detector can be fulfilled either solely by a photometer head or with the additional use of an optical probe for a spectroradiometer. Both devices are located in a stray light tube which minimizes any undesired extraneous

light during measurement. The distance between the detector and the luminaire is fixed and limited by the design, so that the condition for photometric limit range is only met for small sources. However, this is not necessary for determining the luminous flux by integration of the illuminance distribution. A maximum dimension of the source can be specified depending on its emission angle. This permits additional luminous intensity distributions and all photometric and colorimetric spatial radiation patterns in the far field. Each light source was burned in with its standard burning position before measurement was carried out with a luminous flux integrator.



Image 3: Goniophotometer luminous flux integrator (left) and luminous flux integrator with photometer and spectroradiometer (right).

POSITION CORRECTION

If, as in the case of the turning luminaire goniometer, the operating position of the luminaire deviates during the measurement from its designed burning position, a correction of the measurement values is necessary in conformity with CIE DIS 025:2014 [2]. The measurement results have to be corrected to take account of the characteristic dependence of the burning position for the specific device under test and the actual burning position used. The deviation can be determined with an auxiliary photometer. In order to achieve this, the alignment and the distance of the photometer head to the light source may not be changed during the movement. This ensures that a change in luminous flux of the DUT, caused by changing the burning position, results in a

proportional photocurrent. A correction factor is determined and applied for each position of the goniophotometer approached with reference to the photometer value in the standard burning position. A special software routine allows the position correction to be easily carried out using the auxiliary photometer method [1]. The software helps to save measuring time with specific instructions during the correction run and avoid wrong implementation of the correction. Since the position correction can be carried out directly after the measurement with the turning luminaire goniometer, this avoids the long burn-in of the light source and the additional time required is reasonable. The standard allows a typical position correction to be used when testing a large number of similar types of light source. This also saves valuable measuring time.

TEST COMPARISON

Table 1 summarizes the results of the luminous flux measurements of various light sources carried out using the luminous flux integrator, with the photometer and with a spectroradiometer as a detector, and compares these with the results obtained by means of the turning luminaire goniometer. The measurement results of the luminous flux integrator carried out using the photometer serve as reference values for calculating percentage deviations. The results are very consistent particularly if you consider that different measuring systems with varying geometries and calibrations are involved. Since all measurement deviations are within typical measurement uncertainties for the individual systems, a dependence on the burning position cannot easily be concluded. Rather, a systematic measurement deviation of approximately 1% can be identified in the measurements with the spectroradiometer and the photometer used as a detector in the luminous flux integrator. This allows the burning position of the luminaire to be maintained and the measurements to be carried out in sequence. If you also consider that the measurement can take up to an hour using the spectroradiometer and just a few minutes with the photometer, the scatter of the measurement results for the devices under test without temperature stabilization is even less critical.

Light source	Emission angle	Φ_v [lm] Luminous flux integrator	Φ_v [lm] Luminous flux integrator		Φ_v [lm] Turning luminaire goniometer	
		Photometer	Spectroradiometer		Photometer	
SSL downlight 1	97°	798.0	806.0	1.0%	806.9	1.1%
SSL downlight 2	80°	665.3	673.5	1.2%	671.9	1.0%
SSL downlight 3	52°	1834	1854	1.1%	1878	2.4%
SSL downlight 4	29°	403.0	408.7	1.4%	409.4	1.6%
LED module with heat sink	104°	1167	1181	1.2%	1178	0.9%
LED floodlight	103°	1697	1693	-0.2%	1743	2.7%
Sun lamp (halogen)	32°	4150	4231	2.0%	4021	-3.1%

Table 1: Comparison of the luminous flux measured with the luminous flux integrator (both detectors) and the turning luminaire goniometer for different light sources.

The measurement deviations of the turning luminaire goniometer are comparatively low with respect to the measured value of the luminous flux integrator, although the light sources are continually changing their burning position and the movement leads to cooling and may therefore exert an impact on results. The deviation is so low in particular for all the SSL downlights and an LED module with installed heat sink that a position correction does not appear to be appropriate. It is not surprising that the rotation of the downlights about the *C*-axis during the measurement with the turning luminaire goniometer does not cause any change in the luminous flux because the fins on the heat sink are configured symmetrically around the luminaire. Active cooling in the LED module with a cooler is not position dependent, as expected. Even if the deviations are relatively low in a 30 W LED floodlight and a 300 W halogen lamp with a gas mixture which simulates the sun, a position correction can be applied here as described. The corrected luminous fluxes improve by comparison with the luminous flux integrator and the deviation is just 0.3% for the LED floodlight and -0.9% for the sun lamp (see Table 2). One reason for the slight position dependence of the LED floodlight could be the configuration of the cooling fins on the heat sink which are aligned in a parallel direction and may cause a slight variation in cooling behavior when being rotated at the turning luminaire goniometer. A variation in the measured illuminance was also observed while the position correction was being determined. Rotation of the sun lamp can lead to movement of the gas mixture within the lamp and this may cause a

deviation in measurement. However, the observed effects should actually be higher within the typical measurement uncertainties and the position dependence of the device under test should be higher in order to assess the application of the position correction shown.

Since an SSL downlight with sufficiently high position dependence was not available, this was achieved artificially. The SSL downlight 1 was measured with the turning luminaire goniometer at lower operating voltages (215 V and 200 V) and this inevitably leads to a lower luminous flux (see Table 2). The reference value in the standard burning position at the rated voltage of 230 V was recorded after adequate burn-in time and used for subsequent position correction. The high deviations from the measurement with the luminous flux integrator of -9.5% or -18.4% were again corrected to around 1% after individual application of position correction. Light sources which provide high position dependence can therefore also be measured very easily with the turning luminaire goniometer if subsequent position correction is used in conformity with CIE DIS 025:2014.

	Φ_v [lm] Turning luminaire goniometer		Φ_v [lm] Turning luminaire goniometer with position correction	
LED-Floodlight	1743	2.7%	1702	0.3%
Sun lamp 300W	4021	-3.1%	4111	-0.9%
SSL downlight 1 at 215 V	721.8	-9.5%	805.8	1.0%
SSL downlight 1 at 200 V	650.9	-18.4%	806.9	1.1%

Table 2: Application of the position correction method to the measurements with the turning luminaire goniometer.

DEFINING SPECTRAL CHARACTERISTICS WITH A GONIOPHOTOMETER

LED modules can have different spatial radiation patterns, as shown in Figure 4 using examples of luminous intensity distribution for two SSL light sources. The emission angle can be calculated as the Full Width of Half Maximum (FWHM) for each profile. If the user is only interested in spatial radiation patterns of photometric quantities, such as luminous intensity distribution curves, very fast and precise measurements can be

carried out using a photometer as a detector. If the light-emitting surface is small enough, as is the case in almost all of the SSL light sources investigated here, spatial radiation patterns can also be measured reliably in the far field with the luminous flux integrator. Depending on the emission angle, the distance should be 5 times, 10 times or 15 times the longest dimension of the radiating surface [2]. Only SSL downlight 4 is a boundary case in the current study because strictly speaking the 15-fold distance is not quite fulfilled due to the narrow emission angle of 29° .

However, virtually any distance can be achieved with a turning luminaire goniometer so that the 15-fold distance of the biggest source can always be selected as a precaution. If a photometer is used as a detector, virtually no time is lost. However, a spectroradiometer is essential as a detector if precise colorimetric measurements are required, particularly in the case of the color rendering index (CRI).

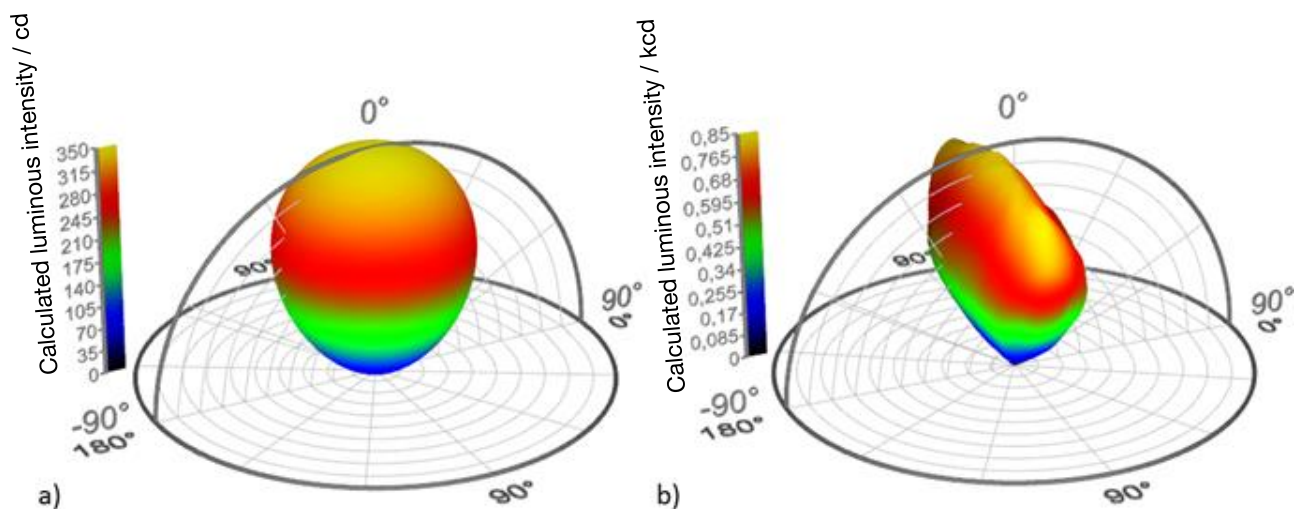

Image 4: 3D representation of the luminous intensity distribution of an SSL light source with 97° (a) and with 104° (b) emission angle, measured with a turning luminaire goniometer.

The spatial distribution of the CRI and the CCT distribution can only be measured with a goniospectroradiometer. Figure 5 shows an example for the polar representation of the spatial distribution of CCT and CRI of an SSL light source with a high color rendering index. A slight directional inhomogeneity with a variation of up to 300 K can be identified in the CCT distribution. The reason for this is probably the positioning of additional red and green LEDs alongside the white LEDs in the module. This increases

the color rendering index to as much as 97. Fine structures in the spatial distribution of the CRI between 95 and 97 can be resolved with a goniospectroradiometer even at this high level of color rendering, as shown in Figure 5b.

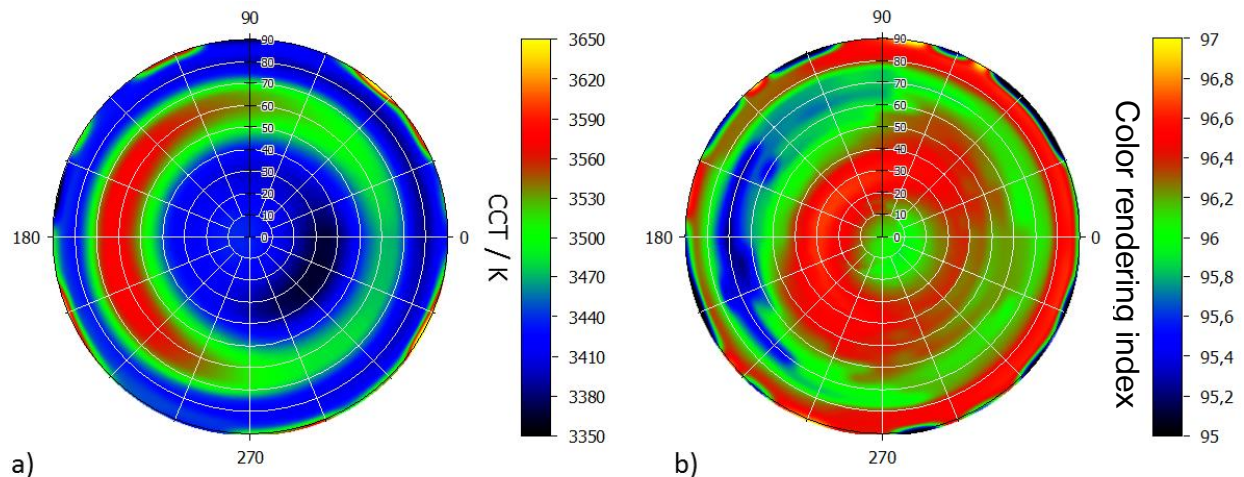

Image 5: Polar representation of the CCT (a) and CRI distribution (b) of an SSL light source, measured with a goniospectroradiometer.

SUMMARY

Goniophotometric comparative measurements with a luminous flux integrator (constant operational burning position) and a turning luminaire goniometer (burning position changes during the measurement) may reveal, at most, minimal dependence on the operating position for the light sources investigated. Nevertheless, an example for the possibility of a position correction using the auxiliary photometer method in conformity with CIE DIS 025:2014 was demonstrated. This allows measurements also to be carried out in conformity with the standard using a turning luminaire goniometer which has a compact footprint and is easy to operate. The auxiliary photometer method allows a user who is not able to carry out such a complex investigation as in this study to verify the applicability of the standard quickly and simply. A position correction can then be carried out as appropriate.

While very fast measurements can be obtained for luminous flux and luminous intensity distribution using a conventional goniophotometer, the spatial distribution of all photometric and colorimetric parameters, e.g. color rendering index (CRI), can only be taken using a goniospectroradiometer. Goniospectroradiometry is therefore an indispensable tool for characterization of SSL light sources on an LED base.

REFERENCES

- [1] G. Leschhorn, Herausforderung der neuen Standardisierung in der Lichtmesstechnik [Challenge of new standardization in light metrology], LICHT 11-12/2014, p. 70-73
- [2] CIE DIS 025/E:2014, Test Method for LED Lamps, LED Luminaires, and LED Modules, CIE Vienna, 2014
- [3] Commission Regulation (EU) No. 1194/2012, Official Journal of the European Union L 342 dated 14.12.2012
- [4] CIE S 014-1/E:2006, Colorimetry Part 1: CIE Standard Colorimetric Observers, CIE Vienna, 2006
- [5] IES LM-79-08, Electrical and Photometric Measurements of Solid-State Lighting Products

Author: Dr. Đenan Konjhodžic, Instrument Systems GmbH, Munich

Diagrams and tables: Instrument Systems, GmbH

www.instrumentsystems.com