

Photonics Industries International, Inc.

FSX Series Femtosecond Lasers

www.photonix.com

With tens of thousands of lasers shipped worldwide, Photonics Industries introduces its FSX Series of femtosecond (fs) lasers. With true fs pulse widths, ~400 fs, it delivers the smallest heat affected zone (HAZ) compared to other "sub ps" (e.g., ~800 fs) lasers also marketed as femtosecond lasers. Furthermore, the FSX Series lasers, with its new revolutionary packaging has smaller form factor and higher performance compared to other fs laser competitors.



The FSX provides from 5W to 80W of IR, with optional green, UV and DUV outputs on the simplest, most compact AIO (All-in-One) platform with up to 40MHz PRF output for processing at highest throughput with polygon scanners.

The user-friendly control interface allows Total Pulse Control and Burst Mode operation, where a user selectable number of pulses with adjustable incremental separation and programable amplitude can be released in an envelope, further enabling ablation rate increases on many materials. With adjustable repetition rate, the user can change the operating PRF and change the operating power or pulse energy through PEC (Power or Pulse Energy Control) function on the fly to maximize process flexibility

Applications

- Ultrafast high precision cutting, drilling, welding, scribing, marking, intra-marking, patterning, de-paneling, repair
- Flat Panel Display Repair, LCD/LED/OLED Repair
- Hydrophobic Material Manufacturing, Hydrophilic Material Manufacturing, Ultrafast Laser Assisted Etching (ULAE) Systems, Complex 3D Surface Micro-structuring
- Terahertz (THz) Generation, High Harmonic Generation (HHG), X-Ray Generation, OPO Amplifier Systems
- Laser Particle Accelerator Systems
- Angle/Time-resolved Photoemission Spectroscopy Systems, Femtosecond-stimulated Raman Spectroscopy (FSRS) Systems, Multi-photon Fluorescence Microscopy Systems

Features

- High power laser (up to 80 W in IR) with ultra-short pulse (~400 fs)
- Variable pulse width (can be increased from specified)
- Wide range of wavelengths: 1030 nm, 515 nm, 343 nm and 257 nm available upon request.
- The most compact, rugged, All-in-One fs laser
- Repetition rates up to 40MHz
- Excellent TEM00 beam with typical M2 ~1.3
- Exceptional Beam Pointing Stability < 20 μrad
- PEC (Power or Pulse Energy Control)
- PSO (Position Synchronized Output) support for external triggering to any arbitrary PRF while maintaining a constant, stable pulse energy with low jitter.
- Burst Mode for individually controllable bursts of pulses with variable separations.
- POD (Pulse-On-Demand), where a burst of pulses with separation equal to the PRF, can be triggered internally, externally, or continuously, while maintaining constant pulse energy.
- Air-cooled option available

Specifications

	FSX-1030-5	FSX-1030-20	FSX-1030-40	FSX-1030-80
Beam and output specifications				
Wavelength	1030 ± 8 nm			
Average power	5 W at 100 kHz	20 W at 1 MHz	40 W at 1 MHz	80 W at 1 MHz
Maximum pulse energy	50 μJ	20 μJ	40 μJ	80 μJ
Pulse width ¹	< 350 fs to 20 ps		< 450 fs to 20 ps	
Pulse repetition rate ²	Single shot to 2 MHz (option up to 40 MHz)			
Pulse-to-pulse stability at 1 MHz	~2% rms			
Long term power stability, 8h ± 1°C	≤ 1% rms			
Beam spatial mode	TEM ₀₀ M ² ~1.3			
Beam pointing stability	< 20 μrad			
Operational specifications and system characteristics				
Interface	RS232, Ethernet, Software GUI, External TTL Triggering			
Warm-up time	< 15 minutes			
Electrical requirement	100-240 V AC; or 32 V DC, 15 A			
Line frequency	50-60 Hz			
Climate	Ambient 15°C to 30°C (59°F to 86°F) Operating Range, Relative Humidity 90% Max., non-condensing			
Power consumption	< 600 W			< 800 W
Dimensions (LxWxH)	24 x 12 x 6.75 in	24 x 12 x 3.73 in	28.5 x 12.5 x 3.75 in	
Weight	~75 lbs	~70 lbs	~80 lbs	
Vibration	Up to 3g			
Cooling system	Air-cooled	Closed-loop chiller		

1. Variable pulse width (can be increased from specified)

2. Lower repetition rates, down to single shot, achieved by utilizing PSO or POD

Pulse energy (μJ) as a function of pulse repetition rate (kHz)

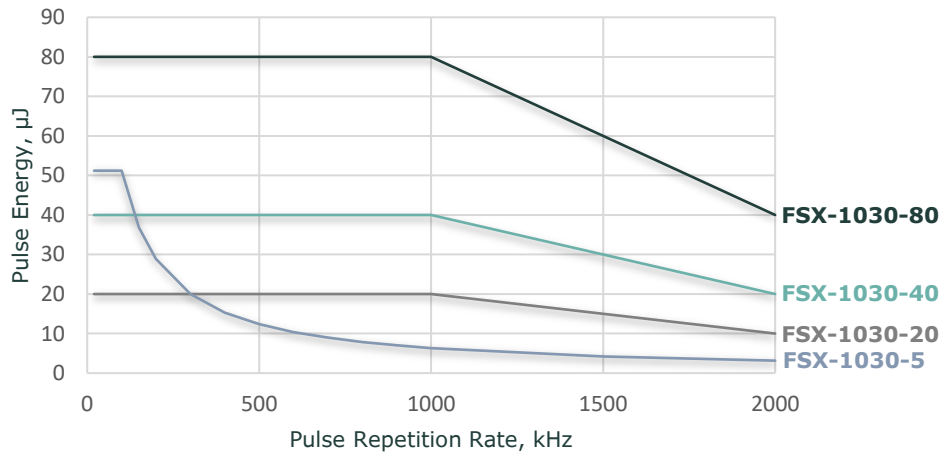

Features

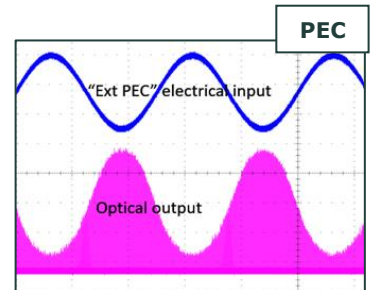
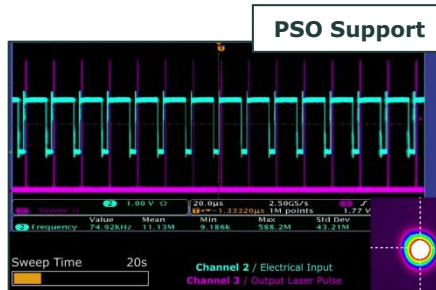
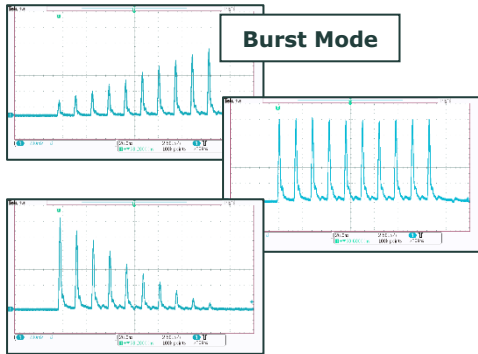

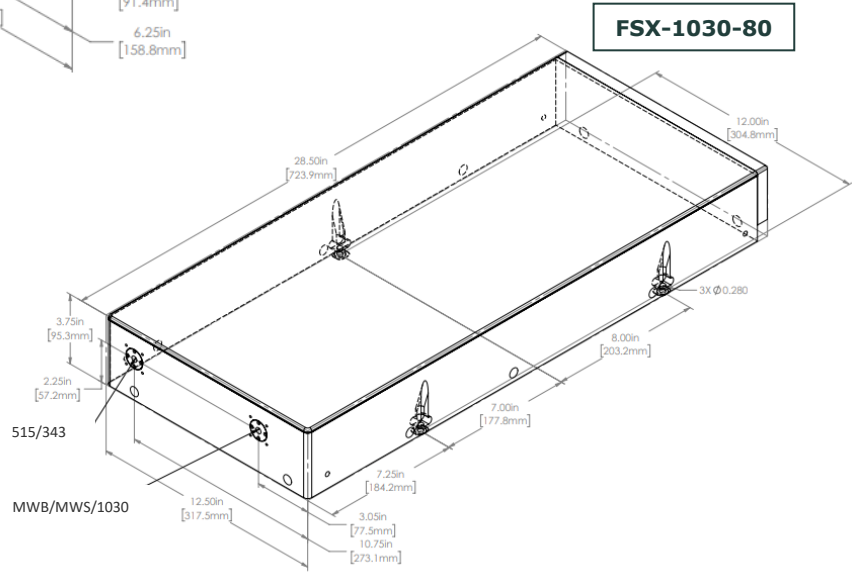
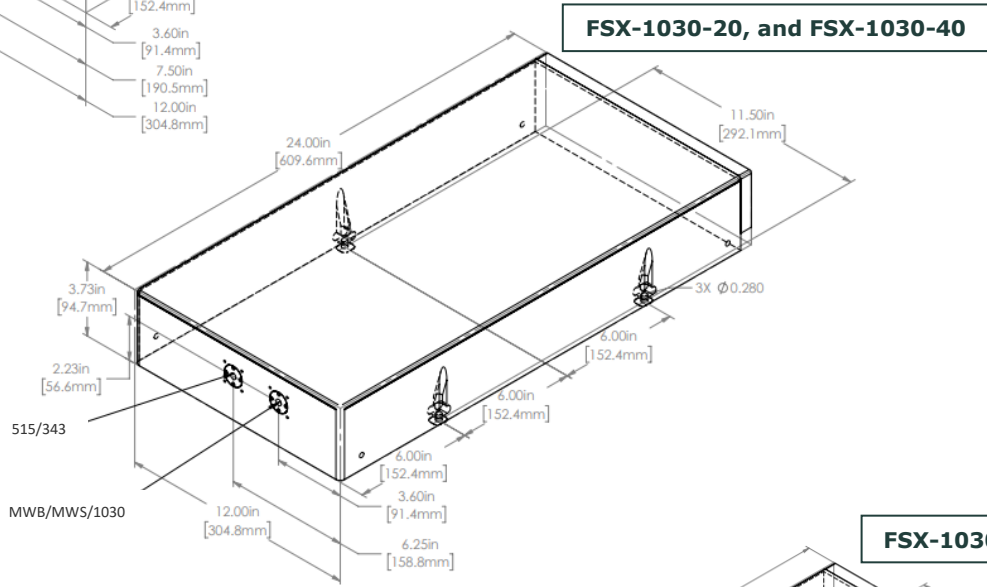
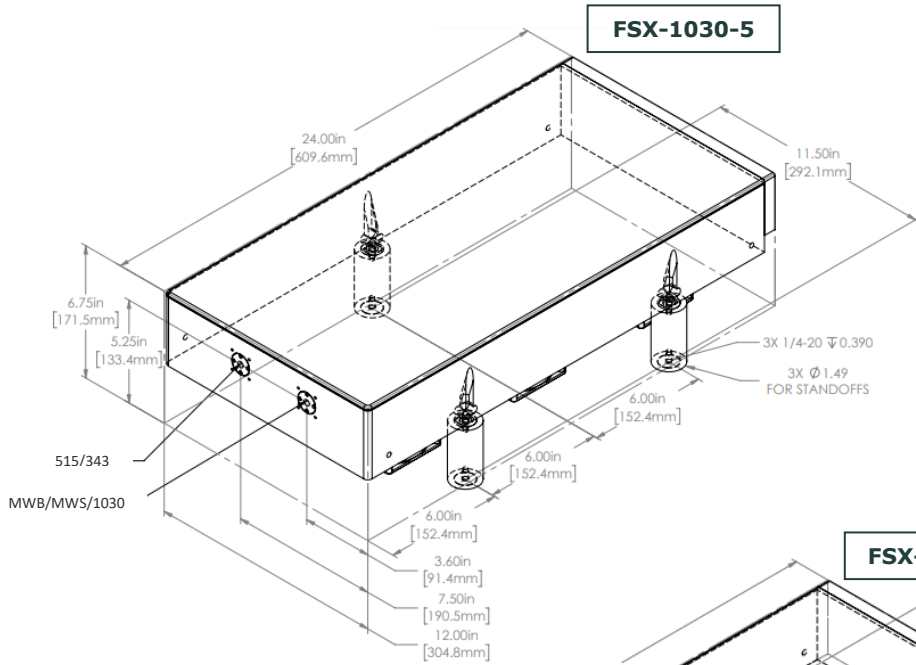

Due to Photonics Industries' commitment to continuous product improvement, specifications and drawings are subject to change without notice.

Photonics Industries conforms to provisions of US 21 CFR 1040.10 & 1040.11 and is made under one or more US patents listed below: 9,531,147, 8,817,831, 7,869,471, 7,346,092, 7,082,149, 7,079,557, 6,999,483, 6,980,574, 6,961,355, 6,842,293, 6,762,405, 6,690,692, 6,587,487, 6,584,134, 6,366,596, 6,356,578, 6,327,281, 6,246,707, 6,229,829, 6,108,356, 6,061,370, 6,028,620, 5,936,983, 5,898,717 and Pending Patents

Copyright © 2022 by Photonics Industries International, Inc.

Main Headquarters: 1800 Ocean Ave, Ronkonkoma, New York 11779, United States

Photonics Industries International is the pioneer of intracavity harmonic lasers and is at the forefront of developing, manufacturing and marketing a wide range of nanosecond, sub-nanosecond, picosecond and femtosecond lasers for industrial, scientific, defense, and medical industries. Check out our [products](#) and see how we can help you [apply](#) our lasers to your needs.

[Website](#) - [Products](#) - [Applications](#) - [Company](#) - [Contact](#) - [International Network](#)

